



Most Widely Accepted and Trusted

ICC-ES Evaluation Report

ESR-2362

ICC-ES | (800) 423-6587 | (562) 699-0543 | www.icc-es.org

Reissued 05/2019
This report is subject to renewal 05/2021.

DIVISION: 06 00 00—WOOD, PLASTICS AND COMPOSITES
SECTION: 06 05 23—WOOD, PLASTIC, AND COMPOSITE FASTENINGS

REPORT HOLDER:

MITek USA, INC.
16023 SWINGLEY RIDGE ROAD
CHESTERFIELD, MISSOURI 63017

EVALUATION SUBJECT:

MITek® STABILIZER™



“2014 Recipient of Prestigious Western States Seismic Policy Council (WSSPC) Award in Excellence”



ICC-ES Evaluation Reports are not to be construed as representing aesthetics or any other attributes not specifically addressed, nor are they to be construed as an endorsement of the subject of the report or a recommendation for its use. There is no warranty by ICC Evaluation Service, LLC, express or implied, as to any finding or other matter in this report, or as to any product covered by the report.



ICC-ES Evaluation Report

ESR-2362

Reissued May 2019

This report is subject to renewal May 2021.

www.icc-es.org | (800) 423-6587 | (562) 699-0543

A Subsidiary of the International Code Council®

DIVISION: 06 00 00—WOOD, PLASTICS AND COMPOSITES

Section: 06 05 23—Wood, Plastic, and Composite Fastenings

REPORT HOLDER:

MITEK USA, INC.
16023 SWINGLEY RIDGE ROAD
CHESTERFIELD, MISSOURI 63017
(314) 434-1200
www.mitek-us.com

EVALUATION SUBJECT:

MITEK® STABILIZER™

1.0 EVALUATION SCOPE

Compliance with the following codes:

- 2018, 2015, 2012, 2009, and 2006 *International Building Code*® (IBC)
- 2018, 2015, 2012, 2009, and 2006 *International Residential Code*® (IRC)

Property evaluated:

Structural

2.0 USES

The Stabilizer™ is used as temporary or permanent lateral bracing for nominally 2-inch-wide wood truss members spaced 24 inches (610 mm) on center.

3.0 DESCRIPTION

The Stabilizer™ is an upside-down U-shaped member formed using steel with a base-metal thickness of 0.036 inch (0.91 mm) that conforms to ASTM A653 SS Grade 40. The steel has a G60 galvanized coating complying with ASTM A653. Each side flange of the U-shaped connector is 1 inch (25 mm) wide, and the center web is 1½ inches (38 mm) wide. Each end of the connector has two flange tabs that are formed at approximately 71 degrees to the side flanges. These flange tabs create the location points used to establish truss spacing. Each flange tab has a set of integral teeth that are stamped and formed at right angles to the parent metal. Each set of integral teeth is fabricated by punching two teeth into the flange tab with each tooth forming a slot 0.45-inch long (11 mm) and 0.125-inch wide (3 mm). When the flange tabs are formed, the remaining steel produces a web tab that laps over the member being braced. Four

series of teeth are stamped and formed at right angles to the parent metal into the web tab. The teeth are identical to the teeth formed into the flange tabs. The longitudinal centerlines of the adjacent slots are staggered 0.25 inch (6 mm) in the transverse direction. The transverse centerlines of the slots are staggered 0.15 inch (4 mm) in the longitudinal direction. Each slot has a 0.33-inch-long (8 mm) tooth at each end. Each tooth is additionally shaped into an approximate 22-degree twist at its end. This process of forming flange tabs, web tabs and integral teeth is applied at both ends of the Stabilizer™. See Figure 1.

4.0 DESIGN AND INSTALLATION

4.1 Design:

The maximum allowable axial load capacity of the Stabilizer™ is as shown in Table 1. The wood framing, having nominally 2-inch-wide (51 mm) members to which the Stabilizer™ is attached, must have a minimum specific gravity of 0.42. Lateral bracing design, details and locations must comply with the requirements of IBC Section 2303.4 or IRC Section R802.10.3.

4.2 Installation:

The Stabilizer™ is installed at right angles in the plane of the nominally 2-inch-wide wood truss members by driving the teeth on the web tab of the Stabilizer™ down into the narrow edge of the wood truss member using a hammer. The flange tabs must then be secured by driving the teeth of each flange tab into the face of the truss member. The Stabilizer™ is properly installed when the web tab and flange tabs are flush with the truss member, with the teeth fully embedded into the truss member. The allowable axial load in tension may be increased to the value specified in Table 1 when one 8d or 10d common wire nail is installed through one of the tooth slots of each web tab into the truss member, as illustrated in Figure 2. The Stabilizer™ must be staggered in adjacent truss bays with the web tabs in side-to-side contact.

5.0 CONDITIONS OF USE

The Stabilizer™ described in this report complies with, or is a suitable alternative to what is specified in, those codes listed in Section 1.0 of this report, subject to the following conditions:

- 5.1** The Stabilizer™ is located where there are no wood defects, such as knots.
- 5.2** The Stabilizer™ is limited to use with untreated lumber and dry service conditions.

- 5.3 The Stabilizer™ locations must be on the truss design drawings in accordance with Section 2303.4 of the IBC.
- 5.4 The MiTek® Stabilizer™ is manufactured by MiTek Industries in Hazelwood, Missouri, under a quality-control program with inspections by ICC-ES.

6.2 A quality-control manual.

7.0 IDENTIFICATION

The Stabilizer™ itself or the packaging must be labeled with the manufacturer's name (MiTek), manufacturing location, the product name (Stabilizer™) and the evaluation report number (ESR-2362).

6.0 EVIDENCE SUBMITTED

- 6.1 Test reports on compression, tension and moment capacity.

TABLE 1—ALLOWABLE AXIAL LOAD

| TYPE OF LOAD | CAPACITY ^{1,2} (lbs) |
|---------------------------------------|-------------------------------|
| Tension | 105 |
| Tension (with fastener ²) | 155 |
| Compression | 420 |

For SI: 1 pound = 4.448 N.

¹Wood framing must have a minimum specific gravity of 0.42.

²Fastener must be one 8d or 10d common wire nail installed through one of the slots in the web tab. (See Figure 2.)

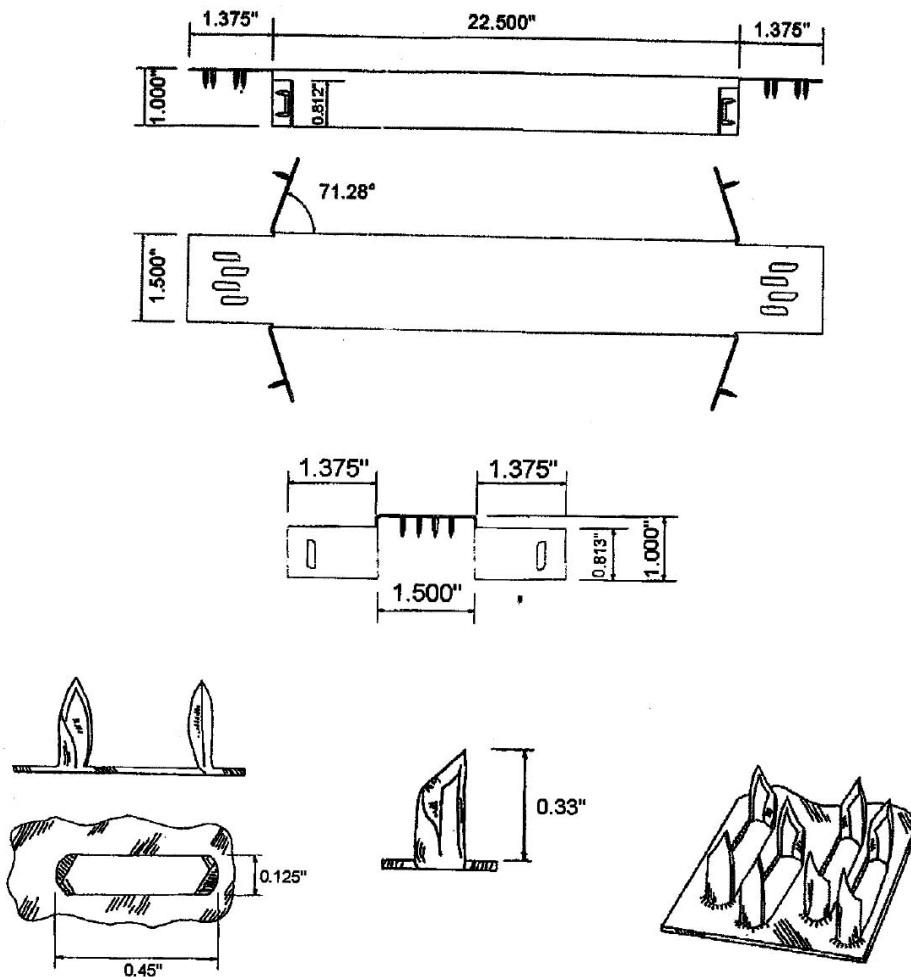

FIGURE 1—STABILIZER™

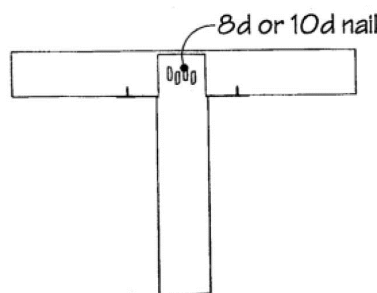

FIGURE 2—FASTENER INSTALLATION

ICC-ES Evaluation Report

ESR-2362 CBC Supplement

Reissued May 2019

This report is subject to renewal May 2021.

www.icc-es.org | (800) 423-6587 | (562) 699-0543

A Subsidiary of the International Code Council®

DIVISION: 06 00 00—WOOD, PLASTICS AND COMPOSITES
Section: 06 05 23—Wood, Plastic, and Composite Fastenings

REPORT HOLDER:

MITEK USA, INC.
16023 SWINGLEY RIDGE ROAD
CHESTERFIELD, MISSOURI 63017
(314) 434-1200
www.mitek-us.com

EVALUATION SUBJECT:

MITEK® STABILIZER™

1.0 REPORT PURPOSE AND SCOPE

Purpose:

The purpose of this evaluation report supplement is to indicate that the Mitek® Stabilizer™, recognized in ICC-ES master evaluation report ESR-2362, has also been evaluated for compliance with Chapter 23 of the code noted below.

Applicable code edition:

2016 *California Building Code* (CBC)

2.0 CONCLUSIONS

The Mitek® Stabilizer™, described in Sections 2.0 through 7.0 of the master evaluation report ESR-2362, complies with CBC Chapter 23, provided the design and installation are in accordance with the 2015 *International Building Code*® (IBC) provisions noted in the master report, and the additional requirements of the CBC Chapters 16, 16A, 17, 17A and 23, as applicable.

This supplement expires concurrently with the master report, reissued May 2019.

ICC-ES Evaluation Report

ESR-2362 FBC Supplement

Reissued May 2019

This report is subject to renewal May 2021.

www.icc-es.org | (800) 423-6587 | (562) 699-0543

A Subsidiary of the International Code Council®

DIVISION: 06 00 00—WOOD, PLASTICS AND COMPOSITES
Section: 06 05 23—Wood, Plastic, and Composite Fastenings

REPORT HOLDER:

MITEK USA, INC.
16023 SWINGLEY RIDGE ROAD
CHESTERFIELD, MISSOURI 63017
(314) 434-1200
www.mitek-us.com

EVALUATION SUBJECT:

MITEK® STABILIZER™

1.0 REPORT PURPOSE AND SCOPE

Purpose:

The purpose of this evaluation report supplement is to indicate that the MiTek® Stabilizer™, recognized in ICC-ES master report ESR-2362, has also been evaluated for compliance with the codes noted below.

Applicable code editions:

- 2017 *Florida Building Code—Building*
- 2017 *Florida Building Code—Residential*

2.0 CONCLUSIONS

The MiTek® Stabilizer™, described in Sections 2.0 through 7.0 of the master evaluation report ESR-2362, complies with the *Florida Building Code—Building* and the *Florida Building Code—Residential*, provided the design and installation are in accordance with the 2015 *International Building Code*® (IBC) provisions noted in the master report.

Use of the MiTek® Stabilizer™ has also been found to be in compliance with the High-Velocity Hurricane Zone provisions of the *Florida Building Code—Building* and the *Florida Building Code—Residential*.

For products falling under Florida Rule 9N-3, verification that the report holder's quality-assurance program is audited by a quality-assurance entity approved by the Florida Building Commission for the type of inspections being conducted is the responsibility of an approved validation entity (or the code official when the report holder does not possess an approval by the Commission).

This supplement expires concurrently with the master report, reissued May 2019.